

P/N :

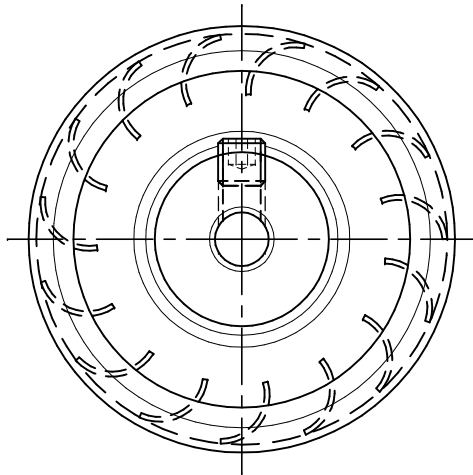

VIEW-A

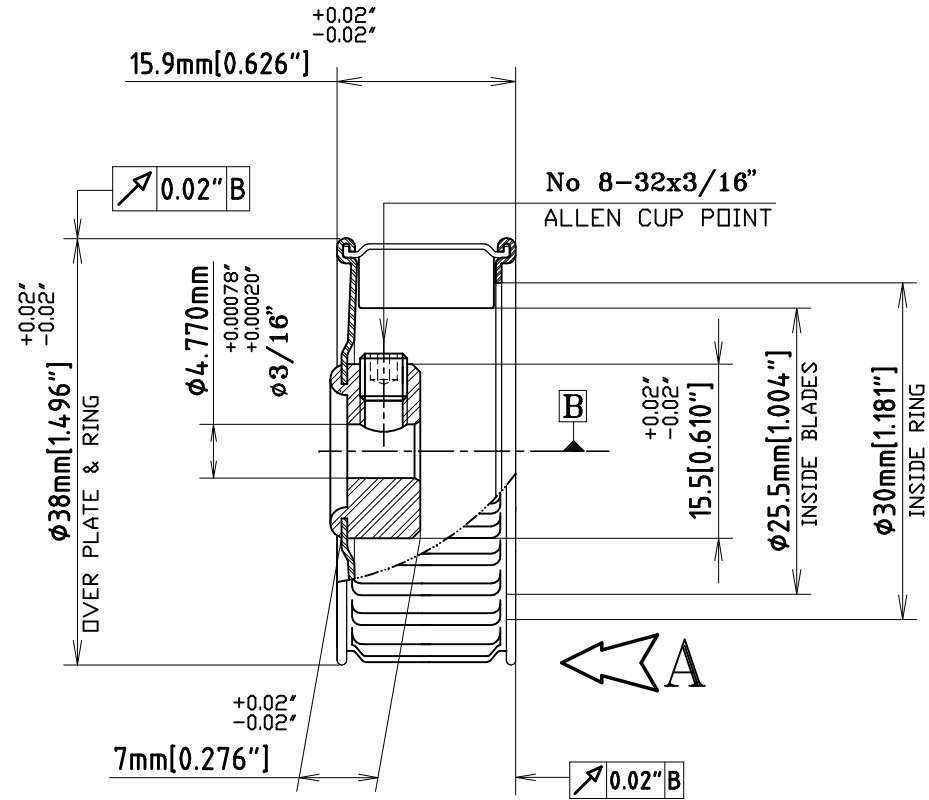

1-MATERIAL :

WHEEL : STAINLESS STEEL 304

HUB : STAINLESS STEEL 303

2-ROTATION FROM VIEWING HUB (A) : CCW or CW

3-No. OF BLADES : 15

4-RUNOUT RADIALY & AXIALY : 0.02" Max

5-STATIC UNBALANCE : 0.0053 OZ.IN Max

Sheffy	26-May-09
Sheffy	08 JUL 07
Drawing Conveyed To	Date

	NAME	DATE	CENTRIFUGAL STRIP WHEELS TYPE IMPELLER : SN150S
DRAWN	A-BEHROZ	12/02/07	
DESIGNED	A-BEHROZ	12/02/07	
CHECKED	ALON	26-May-09	FOR :
Printing		26-May-09	P/N :
PROJECTION			

HI-TECH BLOWERS