





Forward Curved Centrifugal Blower Wheels - STRIP Type - SINGLE Inlet - NH & SPIDER

Constructed of a rigid, one-piece blade strip roll, locked to front ring and back plate.
 Materials: Galvanized steel, aluminum, aluminized steel, stainless steel.
 Standard hub bore sizes: 1/4", 5/16", 3/8", 1/2", 5/8", 3/4", others per request.

One set screw - standard. More screws, key-way, pulling groove - special order.
 Rotation is determined by viewing the hub from the open side.
 Dimensions shown are standard - special sizes may be available upon request.

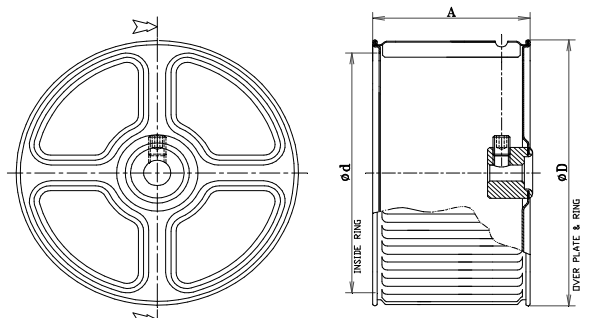
CENTRIFUGAL STRIP WHEELS "NH TYPE" - Single Inlet		
D DIAMETER NH 525" 133mm		A Width
		1.50" 38.0mm
		1.87" 47.5mm
		2.00" 51.1mm
		2.50" 61.5mm
		2.93" 73.5mm
		3.25" 82.0mm
		3.43" 88.0mm
		3.81" 96.0mm
		4.00" 102.0mm
		4.33" 110.0mm
		4.62" 117.0mm
		4.72" 120.0mm
4.72" 120mm		Inside Ring d

CENTRIFUGAL STRIP WHEELS "Spider TYPE" - Single Inlet		
D DIAMETER		A Width
N Spider 7.87" 200mm	N Spider 6.00" 152.4mm	
		2.00" 51.1mm
		2.50" 61.5mm
		2.93" 73.5mm
		3.25" 82.0mm
		3.43" 88.0mm
		3.81" 96.0mm
		4.00" 102.0mm
		4.33" 110.0mm
		4.62" 117.0mm
		4.72" 120.0mm
7.09" 180mm	5.31" 135mm	Inside Ring d
1.63" 41mm	1.02" 26mm	Concave H

